

INTRODUCTION

This 2.5" Snap-in drive bay OEM kit is an ideal solution for equipment that needs a custom fit of a 2.5" removable drive system. This kit shares the same Addonics Snap-in double drive mechanism, except being a single bay and without the mounting frame. This kit is designed for the custom mounting of a 2.5" Snap-In drive bay into equipment that does not have a standard 3.5" drive bay or into a drive bay with a custom bezel.

For application that requires shock and vibration protection on the hard drive, check out the shock mount OEM version, 2.5" Snap-In SP kit.

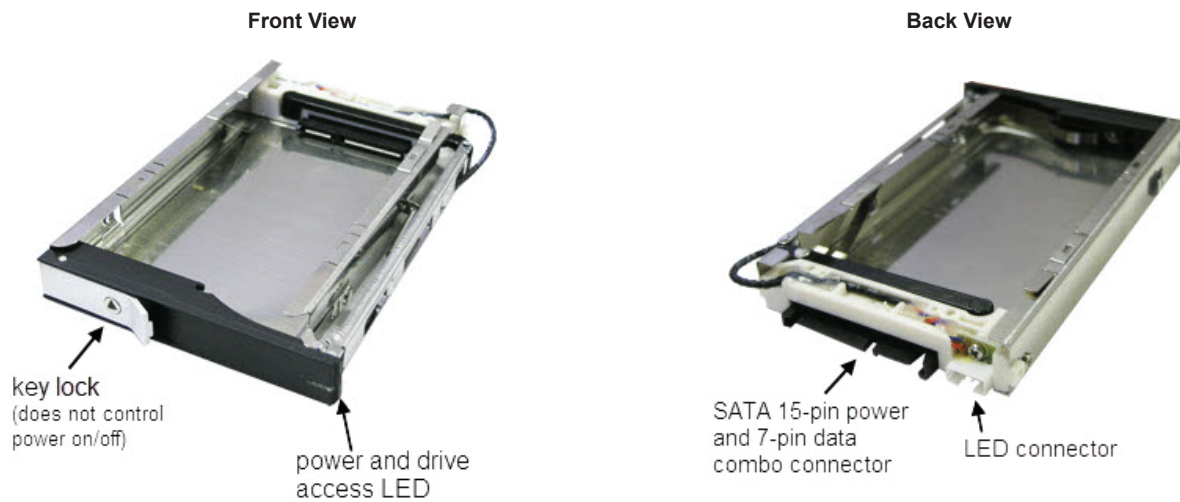

Click on image below to download the PDF version of the detail mechanical drawing

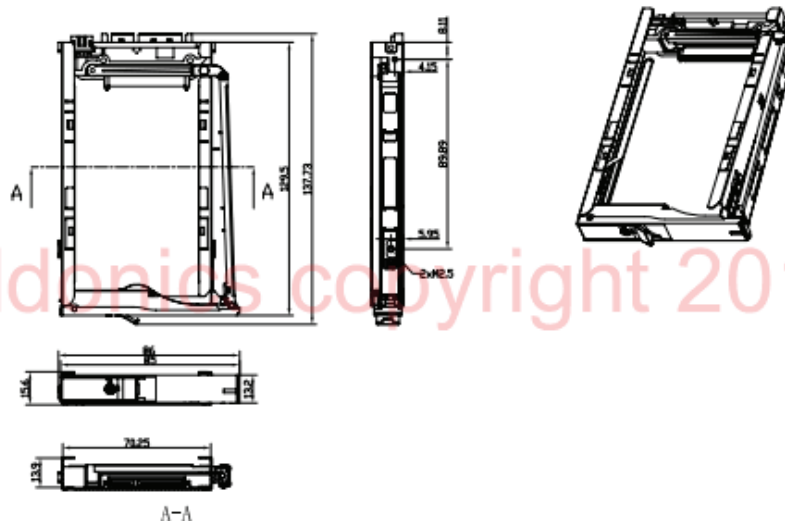

FEATURES

- Custom fit into non standard 3.5" drive bay
- Mount behind 3.5" drive bay with custom front bezel
- Add and remove hard drive from system without any tool or mounting screws
- Accomodate 2.5" SATA hard drives or SSD drives with thickness up to 12.7mm height
- Support SATA I, II and III
- Sturdy steel construction
- Supports hot swap (when connects to controller with this feature)
- Plug and play
- OS independent

For application that requires shock and vibration protection on the hard drive, check out the OEM shock mount version

Package Content

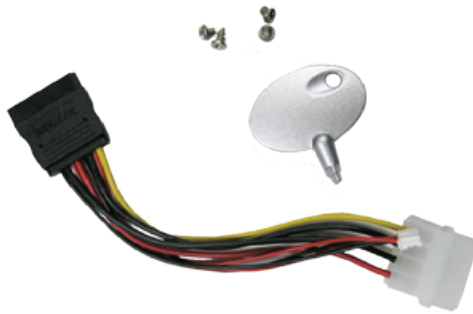

SPECIFICATIONS

Support drive type	2.5" SATA I, II or III hard drive or SSD with drive thickness up to 12.7 mm
Interface Type:	SATA males connectors
Maximum transfer rate	6 Gbps
Construction material:	stainless sheet metal
Power connector:	15-pin SATA power connector
Dimensions:	Click for detail mechanical drawing
Weight:	85 g
Storage Temperature:	Range: -30C to +60C
Operating Temperature:	Range: 0C to +60C
Storage Humidity:	5% to 90%
Operating Humidity:	5% to 95% non condensing
Warranty:	One Year